



OAKLAND

Descriptions

Product code	EC305L33
Product description	OAKLAND Oval table 120(200)x90 natural, lac matt white Oval extendable dining table with white matt lacquered MDF top. Natural color beech wood legs lacquered. Maximum length 200 cm. Get our bag for table extensions and store them when you are not using them!
Origin country	TW

Dimensions

Height x Width x Depth (cm)	74 cm	x	120 - 200 cm	x	90 cm
Product weight (Kg)	38,7 Kg				
Top thickness (mm)	25				
Leaf sizes	40 X 90				

Technical drawings



Features

Use (domestic/contract/office)	Domestic
Indoor (yes/no)	Yes
Alfresco (yes/no)	No
Outdoor (yes/no)	No
Extendible (yes/no)	Yes
Adjustable height (yes/no)	No
Foldable (yes/no)	No
Seating capacity	6
Seating capacity fully extended	8
Max. load (kg)	60
Top edge type	Under bevel
Scratch and wear resistance (Mohs scale)	
Hardness (Rockwell method)	

Extension mechanism type	Removable
Number of leaves	2
Stored inside (yes/no)	No
Adjustable feet (yes/no)	No

Materials

Main material	Manufactured wood
Top material	MDF (Medium density fibers)
Top finishing	Lacquered in PU (Polyurethane), Matt
Leaf material	MDF (Medium density fibers)
Leaf finishing	Lacquered in PU (Polyurethane), Matt
Legs material	Beech wood (Fagus Sylvatica)
Legs finishing	Varnished PU
Feet pad type	Felt pad

Assembly

Unpacking time (min)	3
Assembly required (yes/no)	Yes
Difficulty of assembly	Easy
People required	2
Assembly time (min)	20
Assembly suggestions	Put the top upside down and screw the legs. Check and classify all fittings before starting the assembly. Assemble on a soft surface.

Assembly instructions

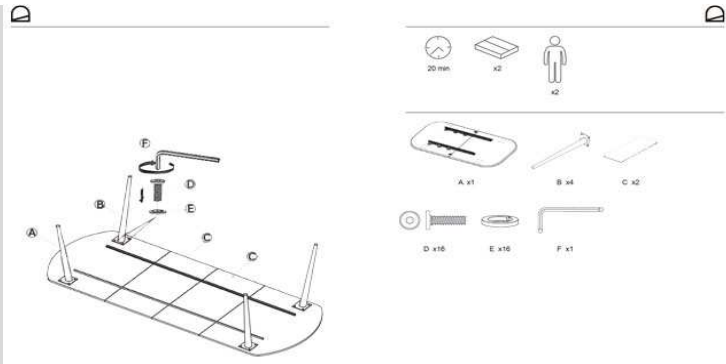

Care & Warranties

General warnings	When using it use a waterproof tablecloth or a coaster. Do not place near direct sources of heat. Keep away from direct solar light. Do not use abrasive products like acetones, bleaches, solvents, etc. Sharp elements can scratch the product surface.
Specific use and care instructions	Clean the product with a wet cloth dampened in a mild cleaner and dry immediately. Dust it with a duster.
Specific use and care instructions for outdoor	N/A
Years of guarantee	2
Made according to	EN 12521:2010 for household use tables
FSC certified (yes/no)	No
PEFC certified (yes/no)	Yes
FLEGT license (yes/no)	N/A
Variation type	No natural variation, Light and environment conditions may distort the color
Purposeful distressing type	No distressing

Additional information	Diameter of the leg on the top: 7 cm. Diameter of the leg on the floor: 3,5 cm. Gloss level: 30 - 40 %. Wood origin country: Spain
------------------------	---

Packaging

Units per lot	
Cbm (m3) / Gross weight (Kg)	0,234 / 42,6
Nº of boxes	2

Box 1	EQUIM46 - 1
Description	OAKLAND Set 4 legs wood natural
Description box	LEGS
Height x Width x Depth (cm)	19 x 76 x 26
Cbm (m3) / Gross weight (Kg) / Net weight (Kg)	0,038 / 6 / 5

Box 2	QUI3L33 - 2
Description	QUIZ Oval Table 120(200) Ext Matt Lac white
Description box	TOP
Height x Width x Depth (cm)	15,5 x 128,5 x 98,5
Cbm (m3) / Gross weight (Kg) / Net weight (Kg)	0,196 / 36,6 / 33,7

Box 3	
Description	
Description box	
Height x Width x Depth (cm)	x x
Cbm (m3) / Gross weight (Kg) / Net weight (Kg)	/ /

Box 4	
Description	
Description box	
Height x Width x Depth (cm)	x x
Cbm (m3) / Gross weight (Kg) / Net weight (Kg)	/ /